

The ISL6740EVAL3Z serves as a reference design for a 48V to $\pm 12V$, 3.3V and 1.5V isolated power supply. It utilizes an ISL6740 double-ended voltage mode controller in half bridge topology to provide an isolated 48V to $\pm 12V$ conversion. An ISL6402 dual PWM controller in synchronous buck topology provides the 3.3V and 1.5V outputs from the +12V rail. The reference design also provides pads to implement an optional LDO using the ISL6402 as a controller.

Specifications

- Input Voltage: 36V to 72V
- Outputs:
 - 3.3V $\pm 1\%$ @ 4A
 - 1.5V $\pm 1\%$ @ 7A
 - 12V +3.5%/-10% (typical) @ 1.5A
 - 12V +3.5%/-10% (typical) @ 1.5A
- Efficiency at full load: 86.8% (72V input) to 90.3% (36V input)

Efficiency is plotted in Figure 1 overload, and for various input voltages V_I . The current shown on the X axis represents load current on the 1.5V output. In this test, the loads on the 3.3V, +12V and -12V outputs were all varied proportionately to the 1.5V load. At 7A (maximum 1.5A load), for example, the 3.3V output load is 4A and the +12V and -12V outputs are loaded at 1.5A each.

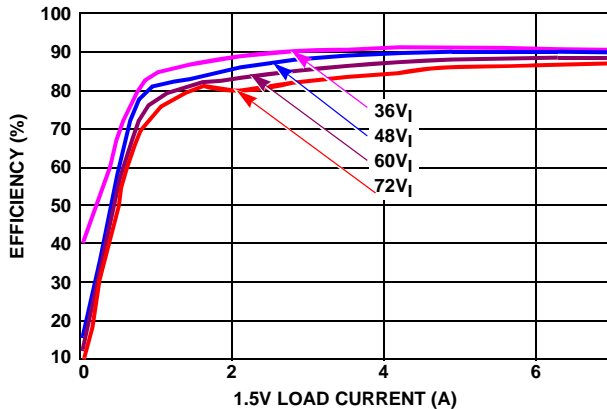

FIGURE 1. EFFICIENCY vs LOAD ON 1.5V OUTPUT. ALL OUTPUTS ARE LOADED IN PROPORTION TO THE 1.5V OUTPUTS' FULL LOAD.

Regulation on the 1.5V and 3.3V outputs is very good over line and load due to individual control loops. The $\pm 12V$ outputs, however, are regulated together. While this saves cost and board space by eliminating additional feedback circuitry, there is a penalty in terms of regulation performance. Figure 2 shows the worst case scenario of an unloaded -12V output with the remaining outputs being stepped from no load to fully loaded. When full load on the +12V, +3.3V and +1.5V outputs is reached, a worst case error of about -10% is seen. Figures 3 and 4 show typical 3.3V and 1.5V output regulation over load.

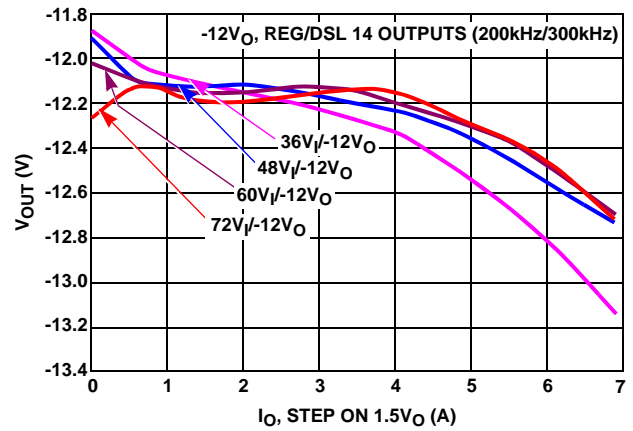

FIGURE 2. -12V OUTPUT VOLTAGE AS ALL OTHER OUTPUT ARE STEPPED FROM UNLOADED TO FULLY LOADED

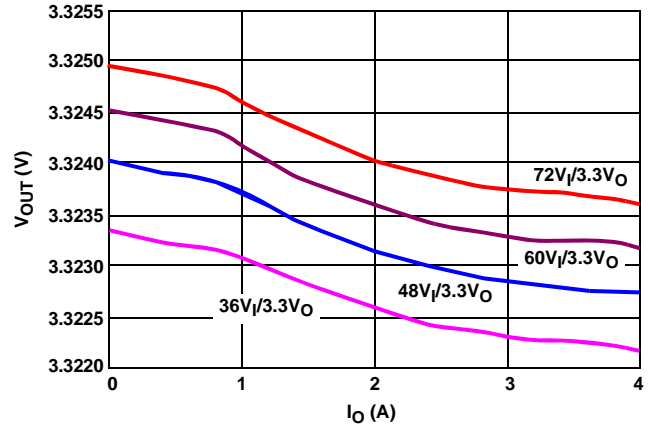

FIGURE 3. +3.3V OUTPUT VOLTAGE vs LOAD

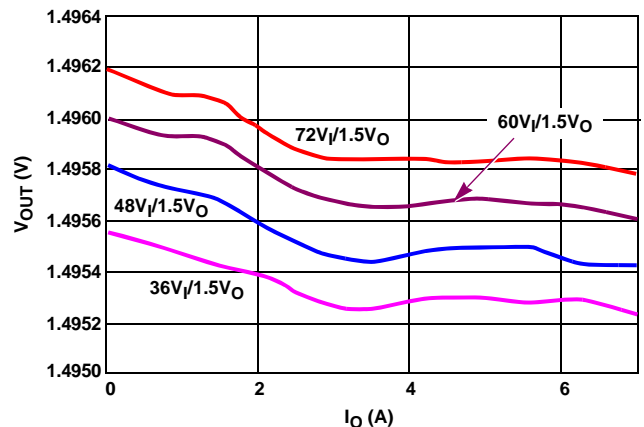

FIGURE 4. +1.5V OUTPUT VOLTAGE vs LOAD

Ripple and noise measurements are illustrated in Figure 5 for an input of 48V, with all outputs fully loaded. In general peak noise + ripple on the test board is 80mV_{P-P}.

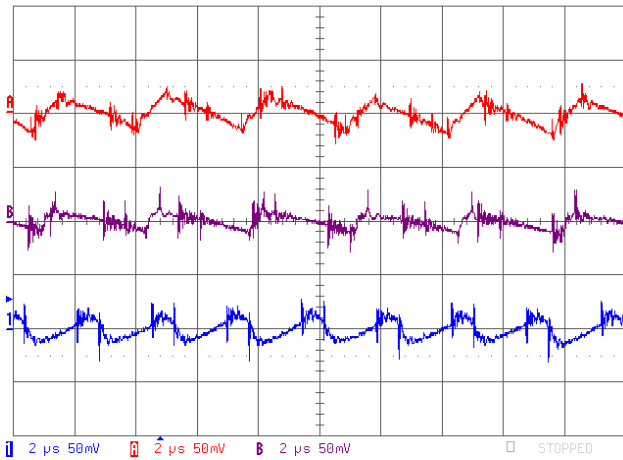

FIGURE 5. NOISE AND RIPPLE AT 48V_{IN}, ALL OUTPUTS FULLY LOADED. FROM TOP TO BOTTOM: +3.3V, +1.5V, AND +12V

Start-up response is shown in Figure 6 for 48V_{IN}, with all outputs fully loaded except for -12V, which is unloaded. The 3.3V and 1.5V start-up responses are independent of input voltage. The 12V output exhibits from 0V to 1V of overshoot as input voltage varies from 36V to 72V.

Figures 7 and 8 show transient responses on the 3.3V line as its load is stepped from 0% to 50% (2A), and from 50% to 0%. Likewise, the transient responses of the 1.5V line are shown in Figures 9 and 10. Figures 11 and 12 show the 24V (+12V to -12V) responses to 25% to 75% and 75% to 25% load steps.

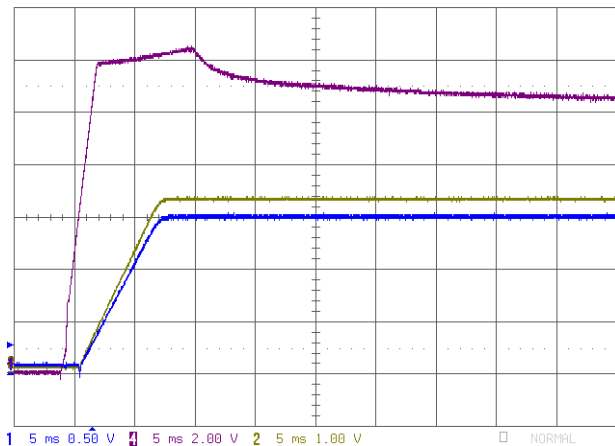

FIGURE 6. START-UP RESPONSE WITH 48V_{IN} AND ALL OUTPUTS FULLY LOADED EXCEPT -12V, WHICH IS OPEN. TOP TO BOTTOM: +12V, +3.3V, +1.5V

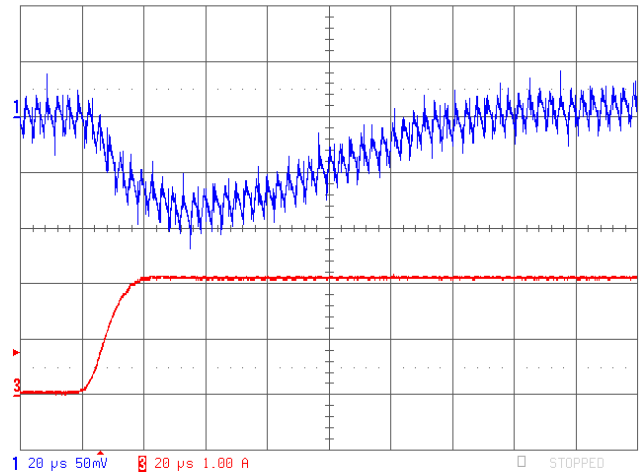

FIGURE 7. TRANSIENT RESPONSE: 3.3V LINE STEPPED FROM 0% TO 50% LOAD. TOP TRACE: 3.3V_{OUT}. BOTTOM TRACE: LOAD (A).

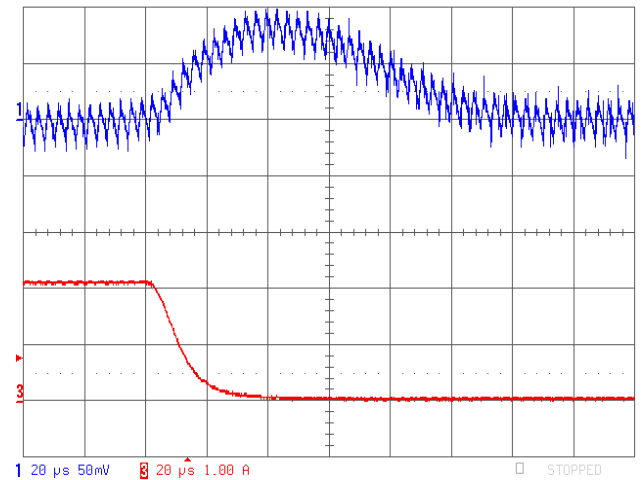

FIGURE 8. TRANSIENT RESPONSE: 3.3V LINE STEPPED FROM 50% TO 0% LOAD. TOP TRACE: 3.3V_{OUT}. BOTTOM TRACE: LOAD (A).

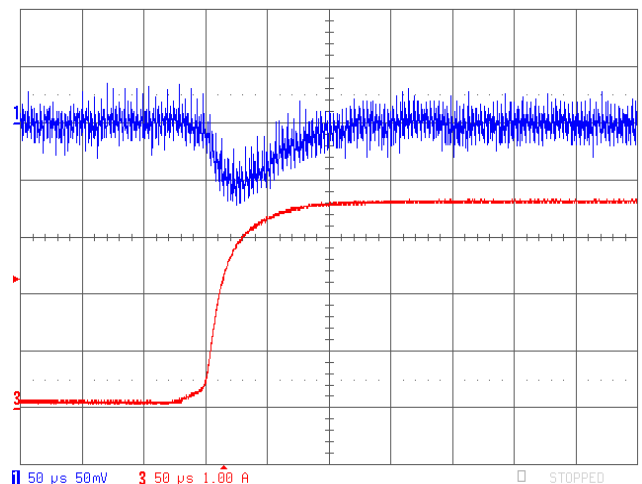

FIGURE 9. TRANSIENT RESPONSE: 1.5V LINE STEPPED FROM 0% TO 50% LOAD. TOP TRACE: 1.5V_{OUT}. BOTTOM TRACE: LOAD (A).

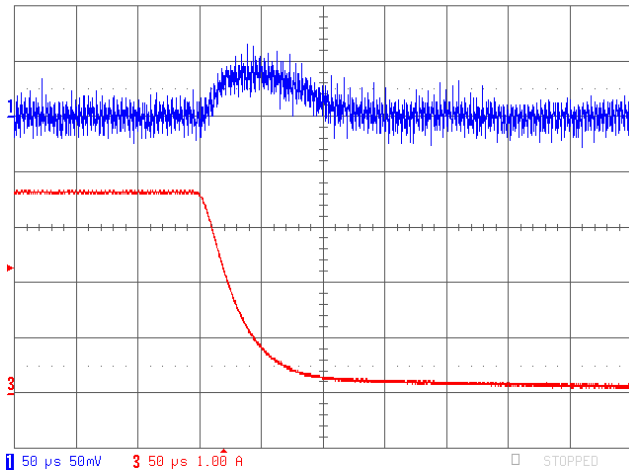

FIGURE 10. TRANSIENT RESPONSE: 1.5V LINE STEPPED FROM 50% TO 0% LOAD. TOP TRACE: $1.5V_{OUT}$. BOTTOM TRACE: LOAD (A).

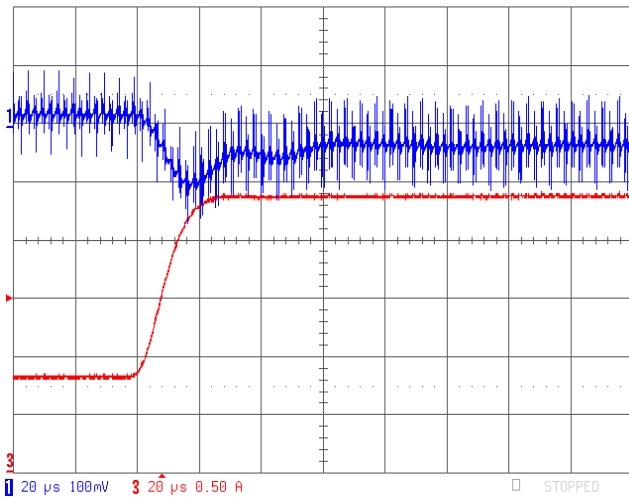

FIGURE 11. TRANSIENT RESPONSE: 24V LINE STEPPED FROM 25% TO 75% LOAD. TOP TRACE: $1.5V_{OUT}$. BOTTOM TRACE: LOAD (A).

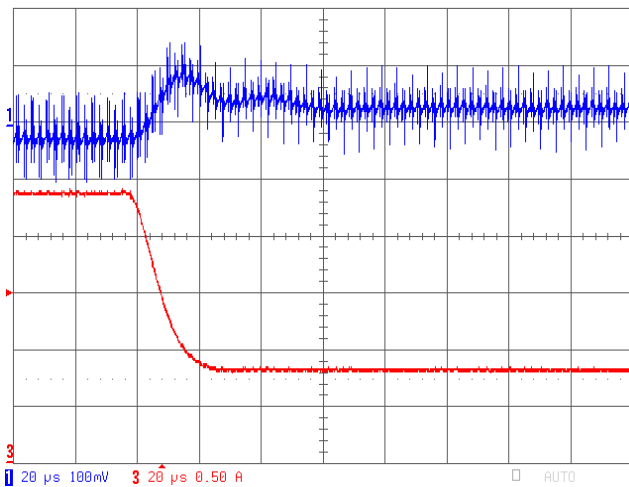

FIGURE 12. TRANSIENT RESPONSE 24V LINE STEPPED FROM 75% LOAD TO 25% LOAD. BOTTOM TRACE: LOAD (A).

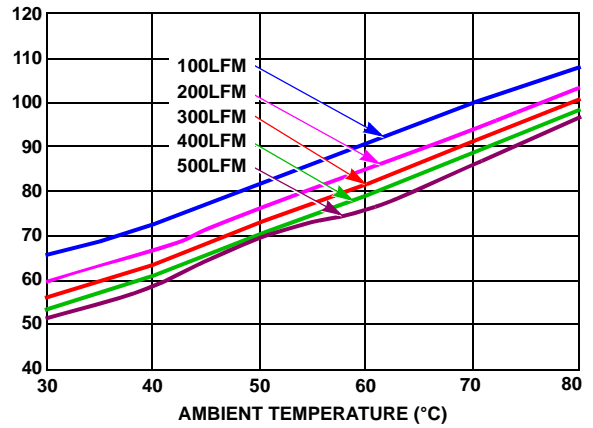

FIGURE 13. HOTTEST PART TEMPERATURE (°C) vs AMBIENT TEMPERATURE (°C) AND AIR FLOW AT 36V INPUT

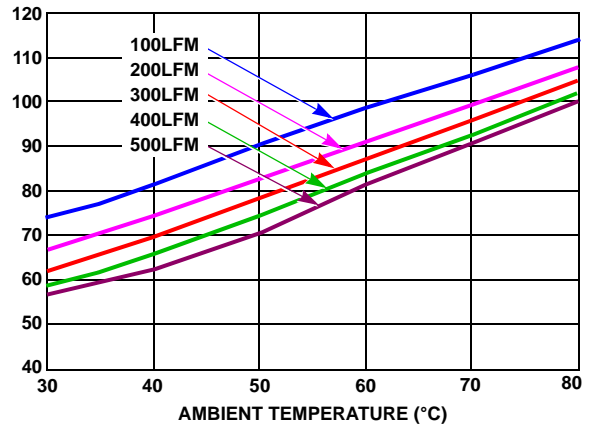

FIGURE 14. HOTTEST PART TEMPERATURE (°C) vs AMBIENT TEMPERATURE (°C) AND AIR FLOW AT 72V INPUT

Thermal data is provided in Figures 13 and 14 for input voltages of 36V and 72V, respectively. These plots show the temperature of the hottest component vs ambient temperature for air flow rates of 100LFM to 500LFM.

Figure 15 shows a thermal image of the board running at an input voltage of 48V. This image was taken with the board running at full power with a 300LFM air flow rate.

Figures 16 through 21 show the layout of the evaluation board. The bill of materials (BOM) and the schematics are shown in the following. This evaluation board has been designed to meet ROHS compliance.



FIGURE 15. THERMAL IMAGE: 48V INPUT, 300LFM AIR FLOW

TABLE 1. COMPONENT LIST

REFERENCE DESIGNATOR	VALUE	MANUFACTURER	PARTS
CR1, CR2	Schottky SMD, 30V, 200mA	Fairchild	BAT54S-T
D3, CR3, D4, CR7, CR8, CR9	Schottky SMD, 30V, 200mA	Fairchild	BAT54-T
CR4	DPAK, 60V, 12A, ROHS	IR	12CWQ06FNPBF
CR6, CR5	100V, 3A, ROHS	IR	30BQ100PBF
C1	1 μ F, 100V, 20%, X7R, ROHS	VENKEL	H1087-00105-100V20-T
C3,C2	3.3 μ F, 50V, 20%, X7R, ROHS	TDK	H1087-00335-50V20-T
C4, C6, C24, C45, C57	1 μ F,16V, 10%, X7R, ROHS	VENKEL	H1046-00105-16V10-T
C5, C31, C52	0.1 μ F, 50V, 10%, X7R, ROHS	TDK	H1045-00104 -50V10-T
C7	1000pF, 16V, 10%, X7R, ROHS	VENKEL	H1045-00102 -16V10-T
C8, C23, C26, C49	22 μ F, 16V, 20%, X5R, ROHS	TDK	H1087-00226-16V20-T
C9, C22, C32, C34, C39, C59	47 μ F, 16V, 20%, ROHS	Sanyo	16TQC47M
C10, C14, C50, C51, C54, C55	1000pF, 50V, 10%, X7R, ROHS	MURATA	H1045-00102-50V10-T
C12, C11	1000pF, 100V, 10%, X7R, ROHS	VENKEL	H1045-00102-100V10-T
C13	560pF, 100V, 5%, NPO, ROHS	TDK	H1045-00561-100V5-T
C15, C16, C18, C41, C44, C47	0.1 μ F, 16V, 10%, X7R, ROHS	MURATA	H1045-00104-16V10-T
C17	220pF, 16V, 10%, X7R, ROHS	TDK	H1045-00221-16V5-T
C19	0.22 μ F, 16V, 10%, X7R, ROHS	TDK	H1045-00224-16V10-T
C20	220pF, 50V, 5%, C0G, ROHS	VENKEL	H1045-00221-50V5-T
R14, R20, R22, R30, R31, R41, R42, D5, Q6, Q9, C60, C61	DNP		DNP
C25, C58	4.7 μ F, 25V,10%, X5R, ROHS	PANASONIC	H1082-00475-25V10-T
C27, C30, C38, C40	220 μ F, 10V, 20%, ROHS	Sanyo	10TPB220M, RADIAL
C21, C28, C33, C35, C36, C43, C48	DNP		
D1	10V, 200mA, ZENER, SMD	PHILLIPS	BZX84C10-T
D2	6.8V, 350mW, ROHS	Fairchild	BZX84C6V8-T
L1, L3	1 μ H, 5.28A, ROHS	Cooper Electronic Tech.	DR73-1R0-R
L2	4.5 μ H, ROHS	Midcom	40748-LF1

Application Note 1127

TABLE 1. COMPONENT LIST (Continued)

REFERENCE DESIGNATOR	VALUE	MANUFACTURER	PARTS
L5, L6	4 μ H, 10.3A, ROHS	Bitech	HM65-H4R0LF
QR1, QR4, QL, QH	N-CHANNEL, 100V, 7.5A, ROHS	Fairchild	FDS3672-T
Q3, Q1	N-CHANNEL, 30V, 30A, LEAD FREE	RENESAS TECHNOLOGY	HAT2116H-EL-E
Q4, Q2	N-CHANNEL, LFPK, 30V, 40A	RENESAS TECHNOLOGY	HAT2096H-EL-E
Q5	NPN, D-PAK369C, 100V, 3A, ROHS	ON Semiconductor	MJD31CG
RT1	10k, ROHS	KOA	H2511-01002-1/10W1-T
R1	3.3, 1%, 1W, ROHS, 2512	VENKEL	H2515-03R32-1W1-T
R2	3.01k, 1%, 1W, ROHS, 2512	KOA	H2515-03011-1W1-T
R3	10, ROHS	KOA	H2512-00100-1/8W1-T
R4, R5, R44, R45, R46	2.2, ROHS	PANASONIC	H2512-002R2-1/8W1-T
R6	200, ROHS	PANASONIC	H2511-02000-1/10W1-T
R7	75k, ROHS	KOA	H2512-07502-1/8W1-T
R8, R9, R10	18.2, ROHS, 2512	KOA	H2515-018R2-1W1-T
R11	100, ROHS	KOA	H2511-01000-1/10W1-T
R12	8.06k, ROHS	KOA	H2511-08061-1/10W1-T
R13	18.2, ROHS	PANASONIC	H2511-01822-1/10W1-T
R15	1.27k, ROHS	KOA	H2511-01271-1/10W1-T
R16, R33	1k, ROHS	KOA	H2511-01001-1/10W1-T
R17	97.6k, ROHS	KOA	H2511-09762-1/10W1-T
R18	3.01k, ROHS	KOA	H2511-03011-1/10W1-T
R19, R34, R39	499, ROHS	KOA	H2511-04990-1/10W1-T
R21	4.99k, ROHS	PANASONIC	H2511-04991-1/10W1-T
R23	21.5k, MF	VISHAY	H2505-02152-1/16WR1-T
R24	2.49k, MF	VISHAY	H2505-02491-1/16WR1-T
R25	10.5k, MF	VISHAY	H2505-01052-1/16WR1-T
R26	12.1k, MF	VISHAY	H2505-02372-1/16WR1-T
R27	7.5k, MF	VISHAY	H2505-07501-1/16WR1-T
R28	23.7k, MF	VISHAY	H2505-02372-1/16WR1-T
R29, R32, R36, R48	100k, ROHS		H2511-01003-1/10W1-T
R37	301, ROHS	KOA	H2511-03010-1/10W1-T
R49, R38	5.11, ROHS	YAGEO	H2512-05R11-1/8W1-T
R47	68.1k, ROHS	VENKEL	H2511-06812-1/10W1-T
R40	86.6k, ROHS	PANASONIC	H2511-05762-1/10W1-T
T1	6,83 μ H, 25%, 10kHz, CUSTOM, ROHS	Midcom	31660-LF1
T2	CT, SMD, 8P, 500 μ H, 10A, ROHS	Pulse	P8205NL
U1	HALF BRIDGE DRIVER, ROHS	Intersil	HIP2101BZ
U2	ISO PHOTOCOUPLER, 4P, ROHS	Cal. Eastern Lab	PS2801-1-A
U3	IC-PWM CONTROLLER, ROHS	Intersil	ISL6740IBZ
U4	ROHS	National Semi	LM431BIM3/NOPB
U5	DUAL PWM CONTROLLER, ROHS	Intersil	ISL6402IVZ

ISL6740EVAL3Z Schematics

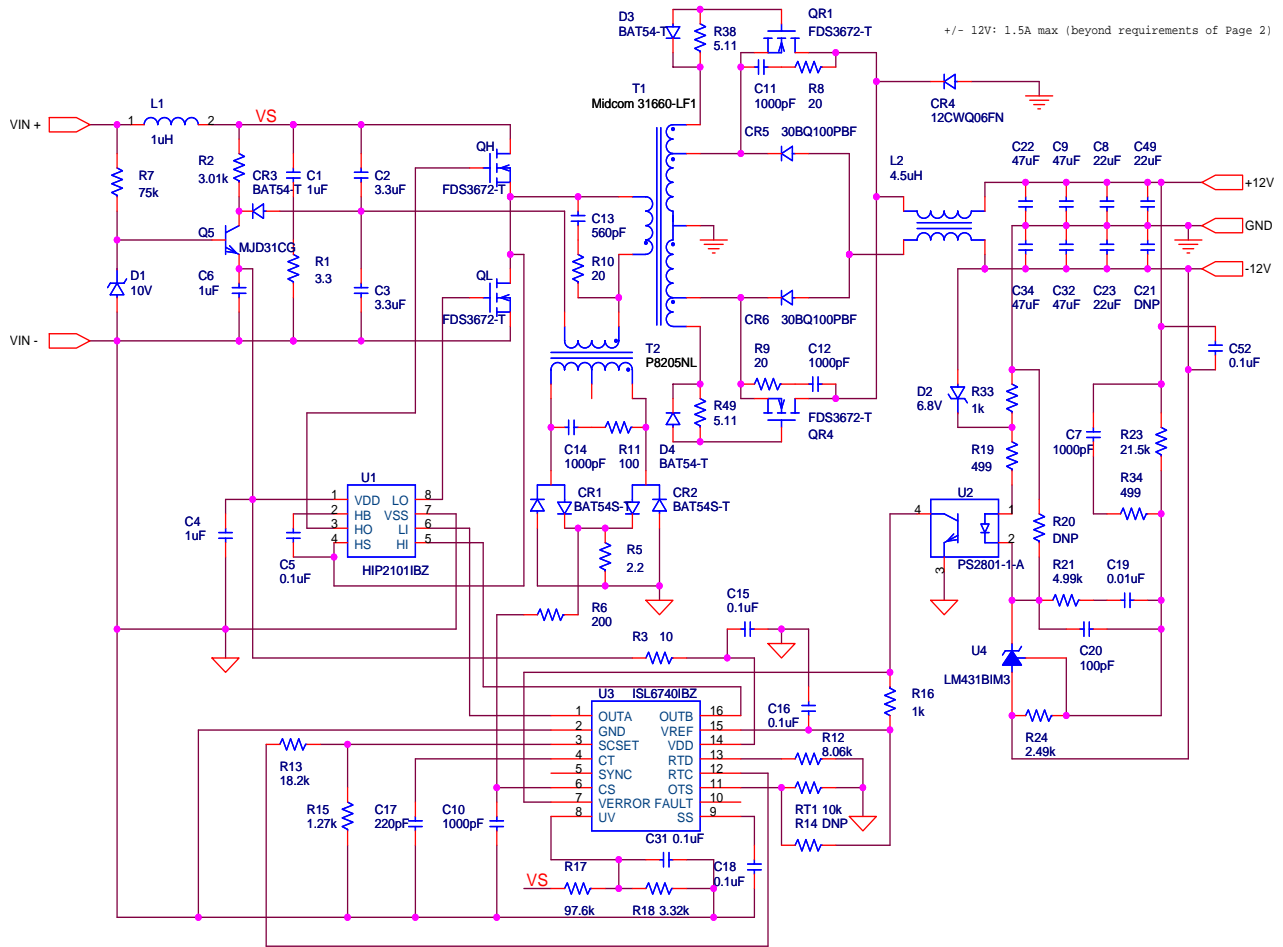

+/- 12V: 1.5A max (beyond requirements of Page 2)

ISL6740EVAL3Z Schematics (Continued)

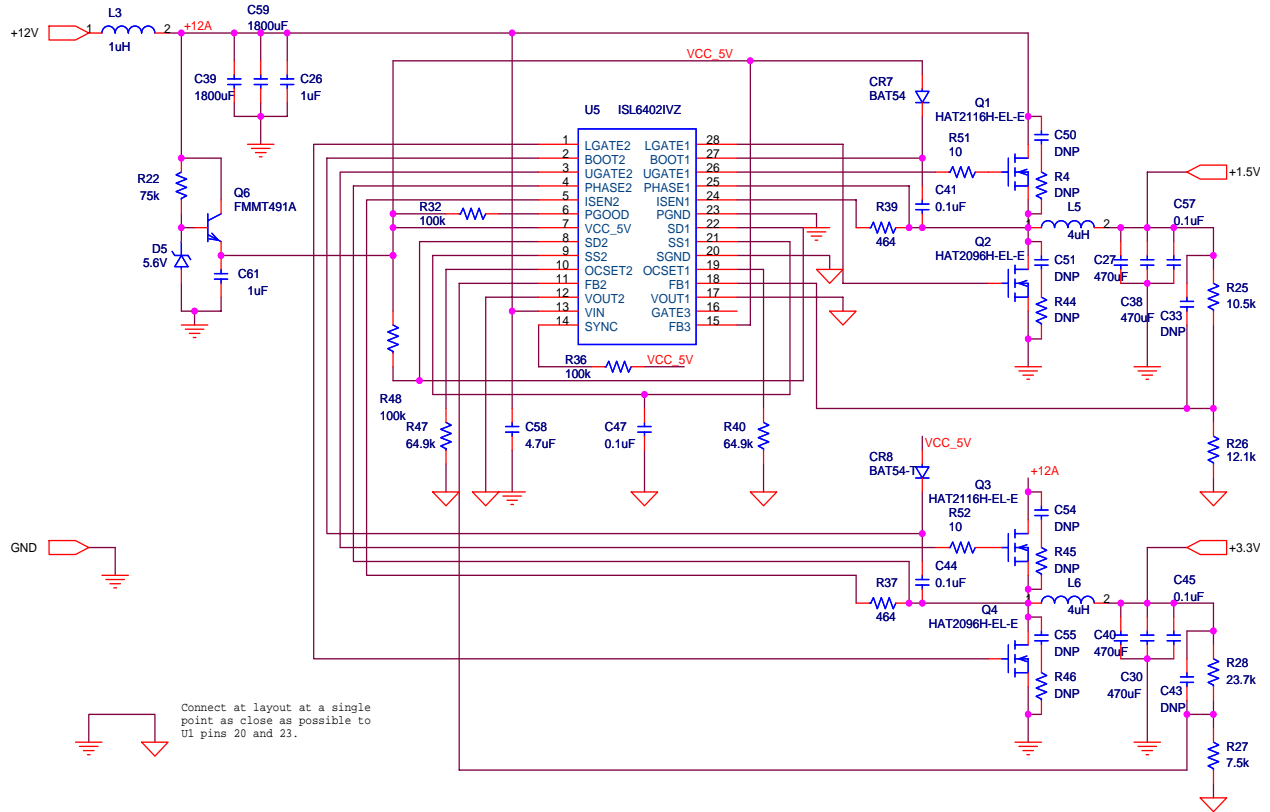

ISL6740EVAL3Z Board Layout

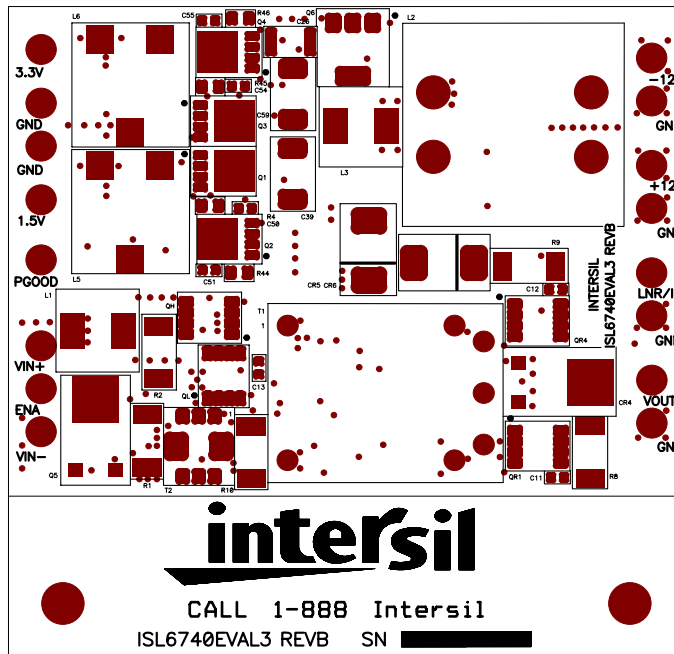

FIGURE 16. TOP LAYER SILKSREEN

ISL6740EVAL3Z Board Layout (Continued)

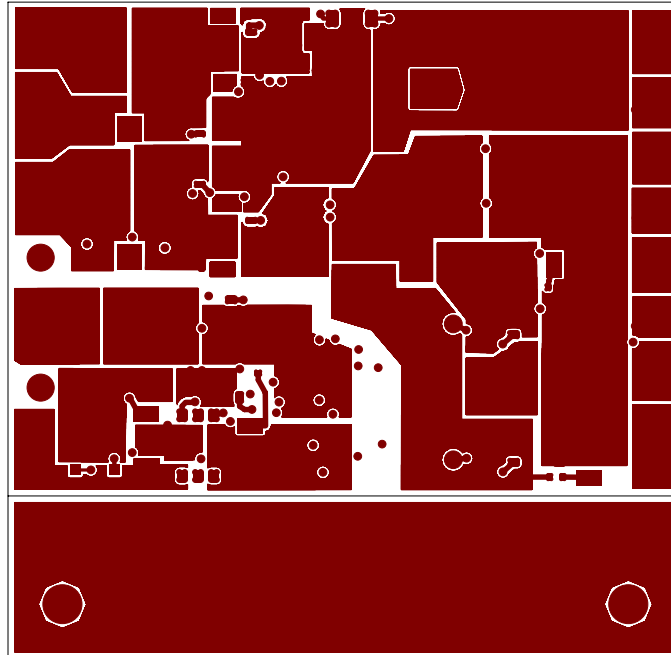

FIGURE 17. TOP LAYER ETCH

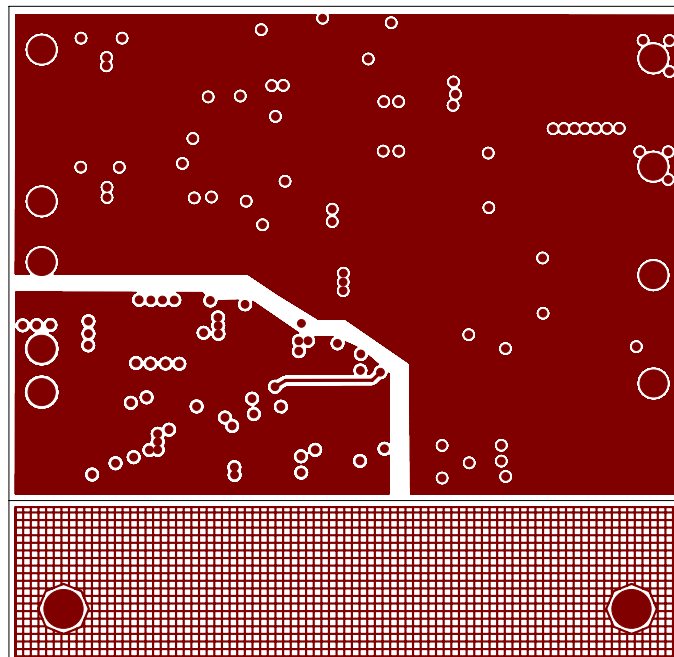

FIGURE 18. LAYER 2

ISL6740EVAL3Z Board Layout (Continued)

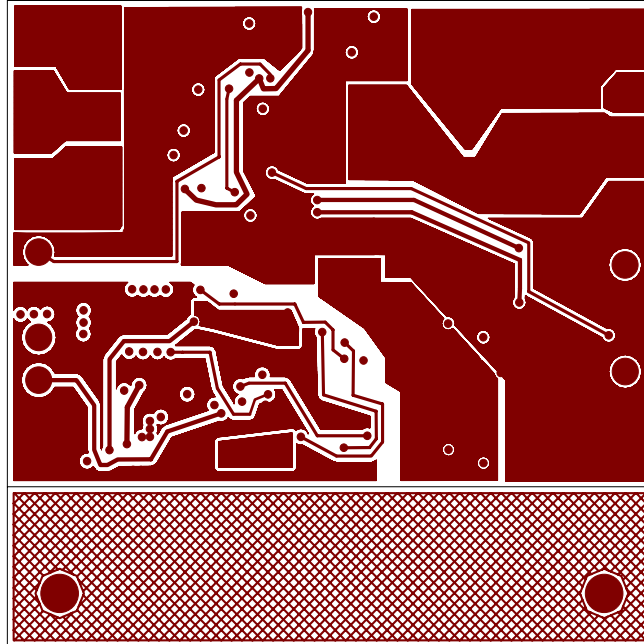

FIGURE 19. LAYER 3

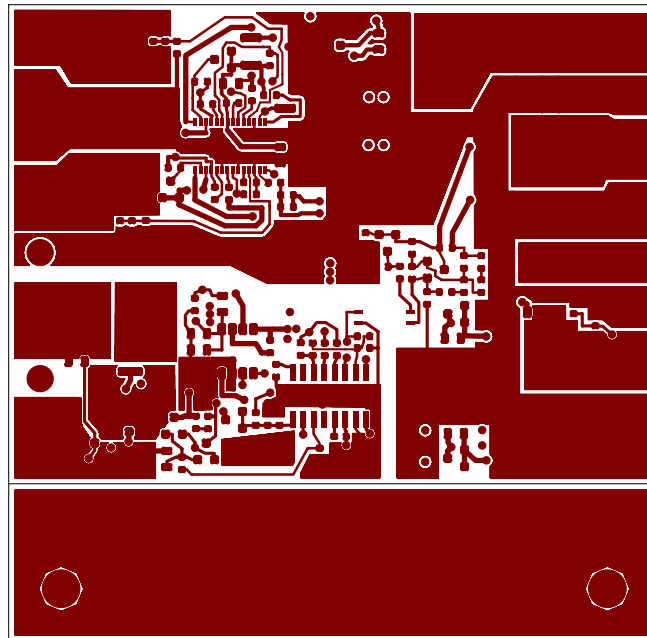

FIGURE 20. BOTTOM LAYER ETCH

ISL6740EVAL3Z Board Layout (Continued)

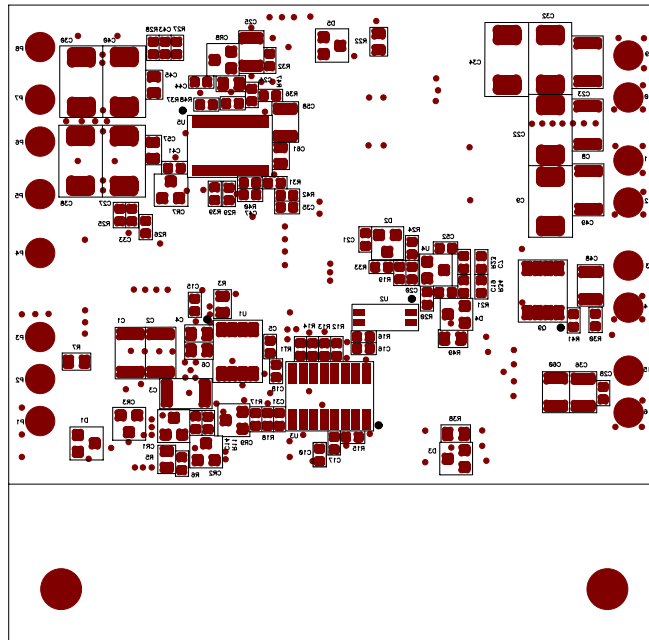

FIGURE 21. BOTTOM LAYER SILKSCREEN

Intersil Corporation reserves the right to make changes in circuit design, software and/or specifications at any time without notice. Accordingly, the reader is cautioned to verify that the Application Note or Technical Brief is current before proceeding.

For information regarding Intersil Corporation and its products, see www.intersil.com